

# ERMEST

[www.ermest.com](http://www.ermest.com)

## S 18 G



**NEW**

## THE BOARDING EXPERTS

\*\*\*

### INNOVATIONS Since 1995

E.R.M.E.S.T. sarl  
rue Jean Colas  
10 440 TORVILLIERS (France)  
Tél : +33 (0) 3 25 74 34 91  
Fax : +33 (0) 3 25 79 55 48  
E-mail : [ermest@wanadoo.fr](mailto:ermest@wanadoo.fr)



# Technical data

---

Capacity of 18 forms.

simple glove (1), thick glove (2), straight forms (3), straightened foot forms (4).

Articles are treated 1 by 1.

Maximum production : 500 pairs per hour.

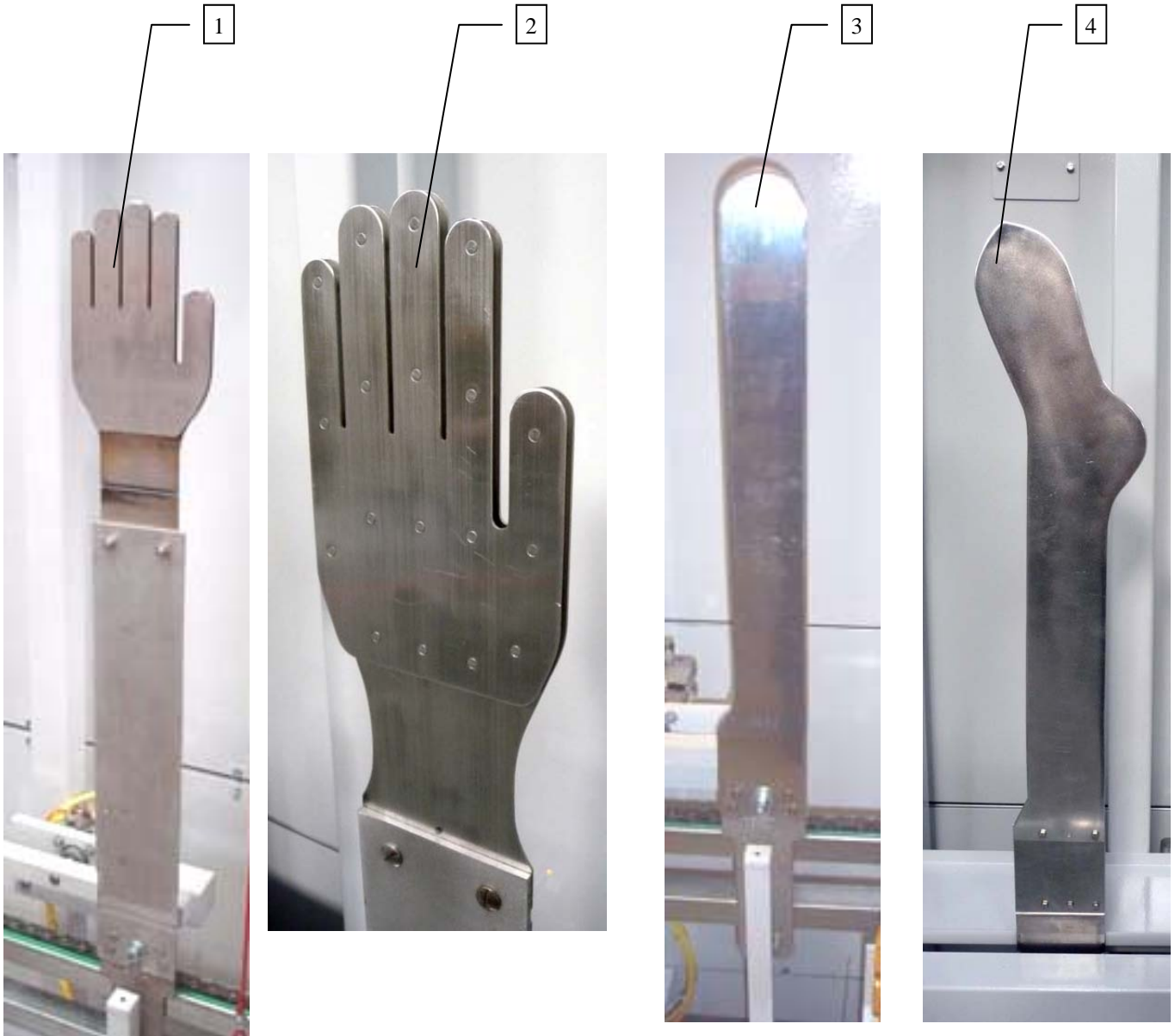

The machine has several positions :

- steam treatment chamber up to 3 bars
- drying with hot air circulation  
( capacity of 5 forms, up to 180°c)
- automatic stripper
- stacking
- banding
- form substitution assistance

All adjustments accessible from the color display.



**Steam treatment up to 3 bars.**

**Uniform steam distribution due to a stainless steel deflector (5).**

**Visual check of the pressure (6).**

**The machine is delivered with a pre-fitted water separator (7).**

**Steam inlet with a 25 ND pipe.**

**Tightness ensured with controlled eccentrics (8)**

**Pressure adjustment manual or automatic. Temperature may be controlled from the display.**

**Rapid change of the sealings due to removable bridles (9).**

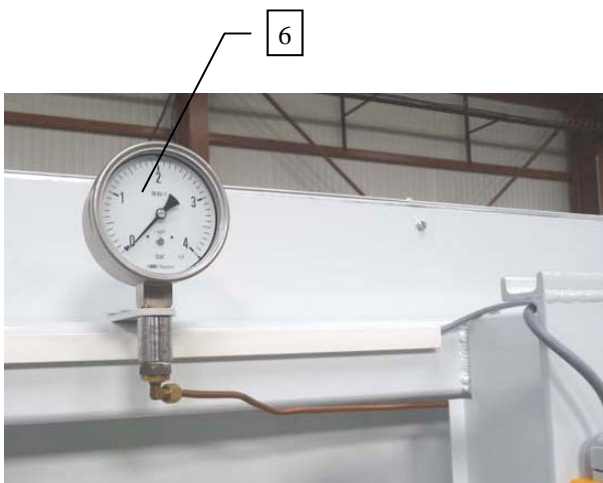
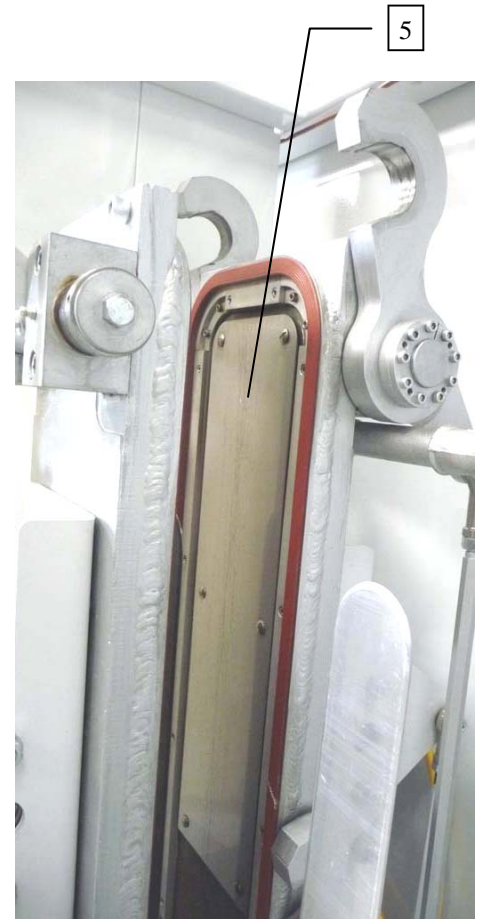

**Drying with hot air circulation capacity of 5 forms, up to 180°, available in 3 versions**

- with electric resistances (22,5 kW)
- a steam exchanger (24 kW)
- a steam exchanger (24 kW) + electric resistances (7,5 kW)

The dryer is fitted with blowing nozzles (10) canalising the air flow very close to the sock.  
Drying temperature adjustable up to 180°C.  
The dryer is insulated with a very thick rock wool layer.  
Openings are reduced to the minimum with flaps (11) in order to reduce the loss of hot air to the maximum.  
A filter (12) collects dust and fluff.

In most cases, drying is operating at low temperature (about 100°C).

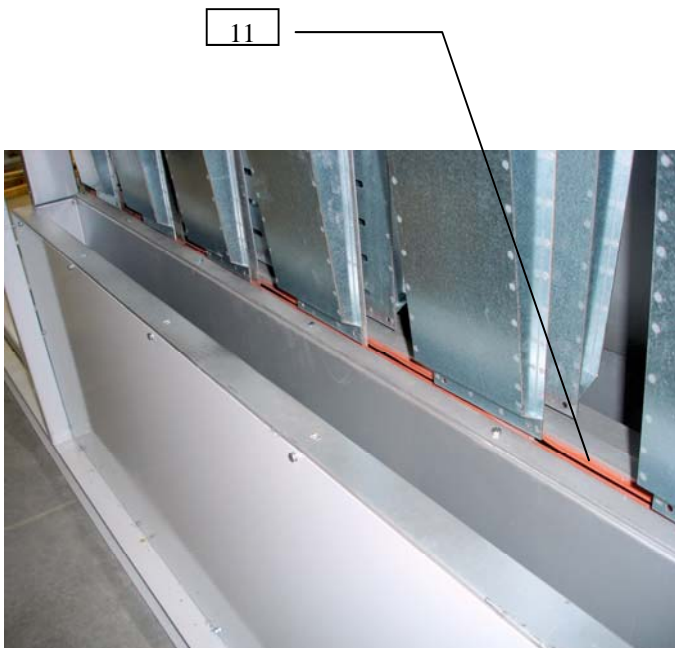
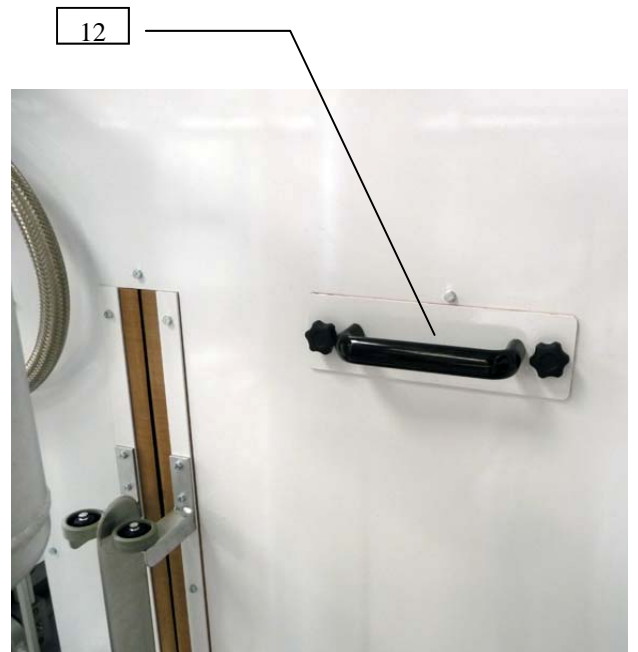
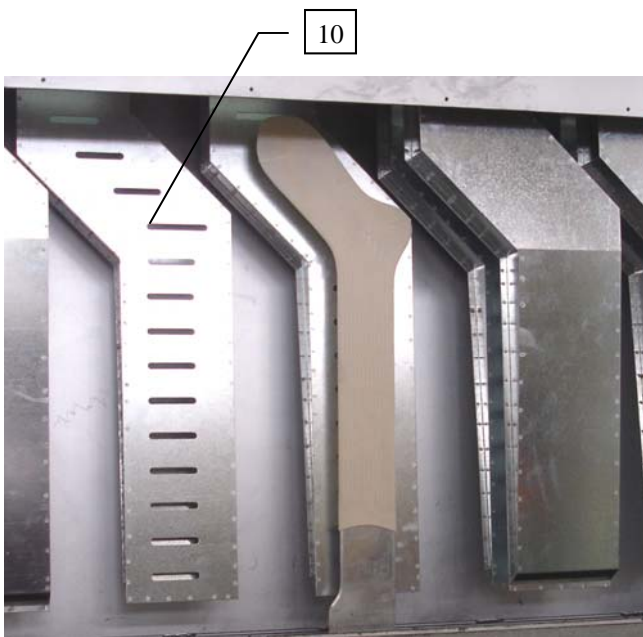

**Automatic stripper composed of a stripper of the belt type (13)**

**Articles are stripped 1 by 1 and delivered by a conveyor (14).**

**The pressure of the belts (13) is adjustable due to regulators (15).**

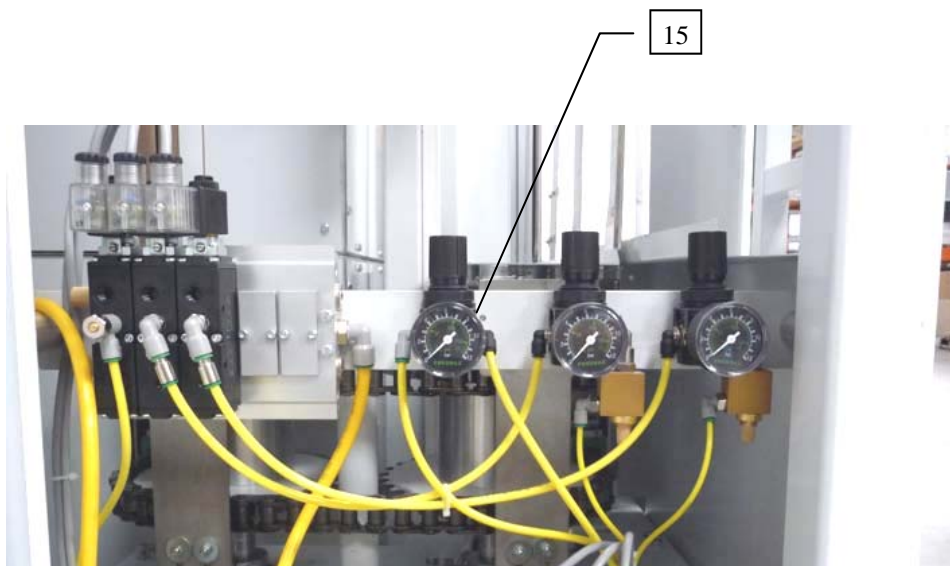
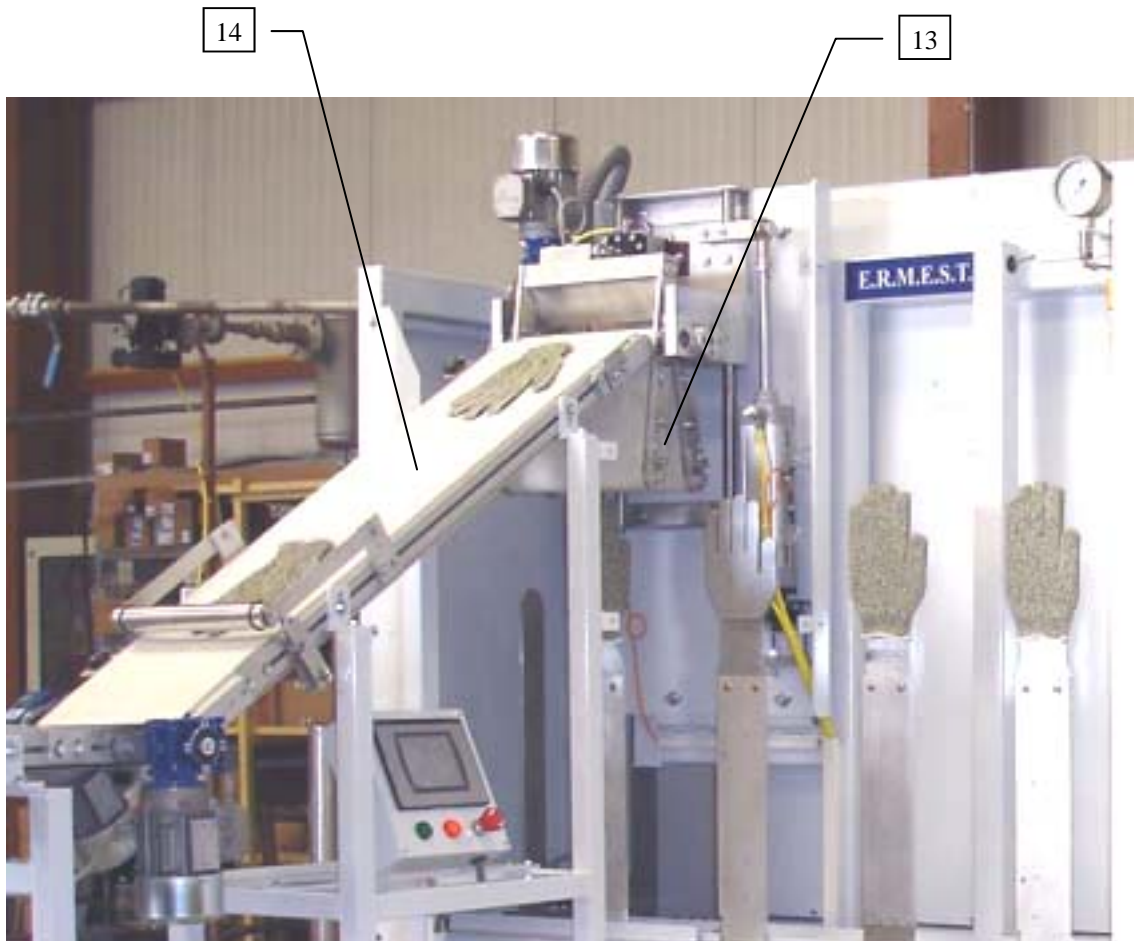

**The form path** is composed of two chains (16), where the form holders are fitted on (17).  
This makes for :

- a good form holding
- quiet operation
- reduced maintenance
- long lifetime

The tension of the chain is ensuring by tensing bearings (18) and springs allowing to compensate wear in the long run.

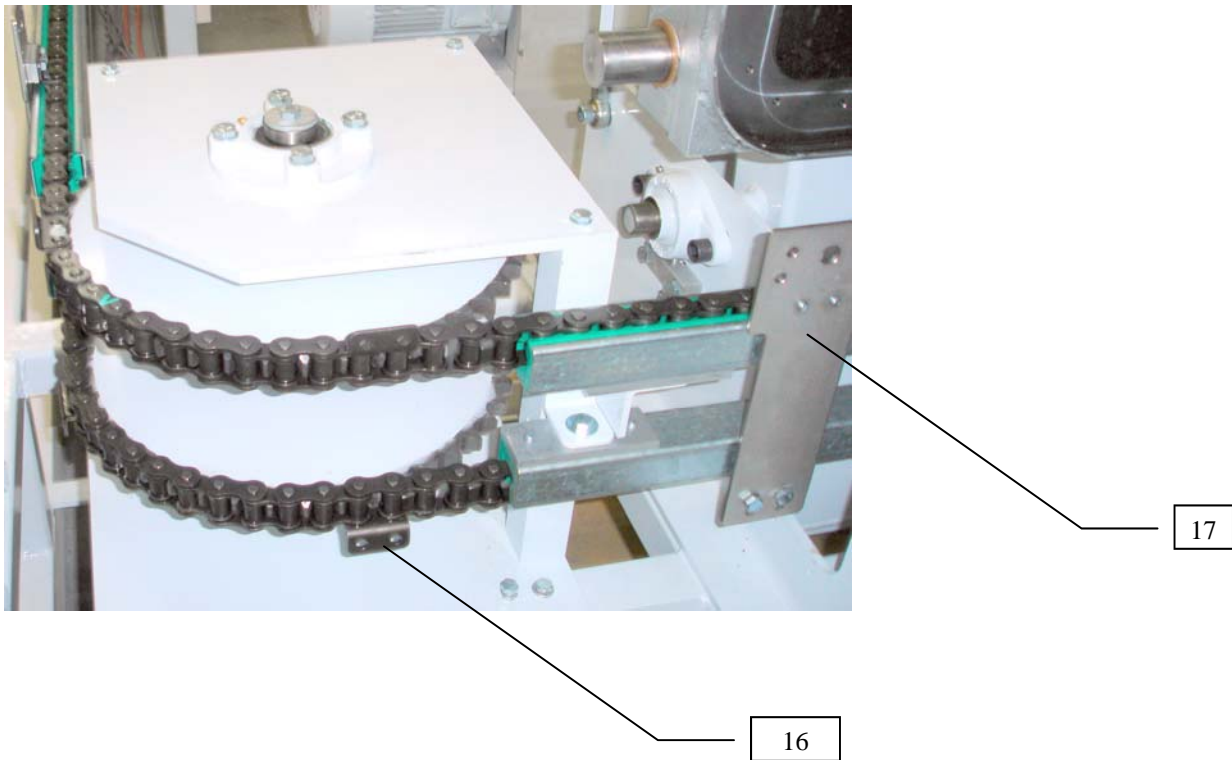

**Quick substitution of forms.**

The springs (19) holding the forms are released by means of a jack (20) controlled by the pedal putting the machine into operation.

The 18 forms are substituted in less than 3 minutes

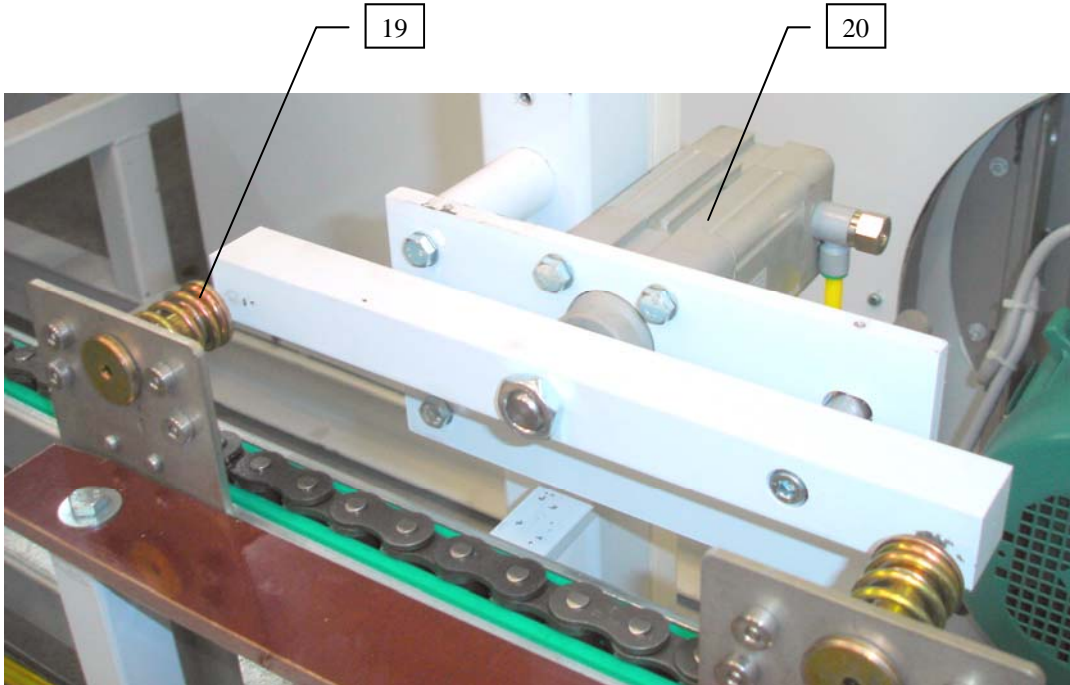

Every parameters (time of treatment, drying temperature, ....) can be preset in fonction of the type of artcile to be treated.

Then you only need to enter a code, to fully settle the machine.

## **Energy consumptions**

---

**Production** : up to 500 pairs per hour.

**Weight** : about 3000 kg

**Indicatives consumptions** :

- electricity                    about 16 kW
- steam                            about 13 kg/h
- compressed air            20 to 30 Nm<sup>3</sup>/h

**Stacking and banding**

As an option, stacking is available (21), staggered or not, and banding (22).

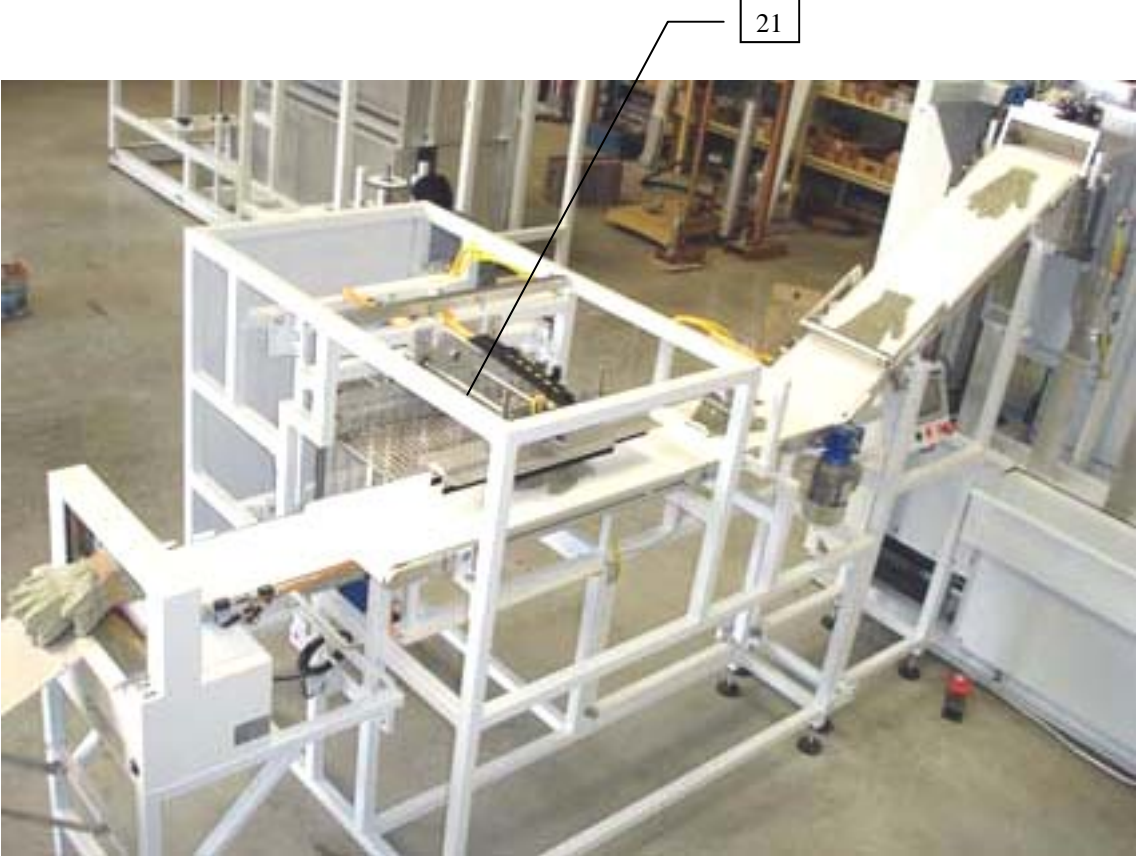



# Floor space dimensions (entire machine)

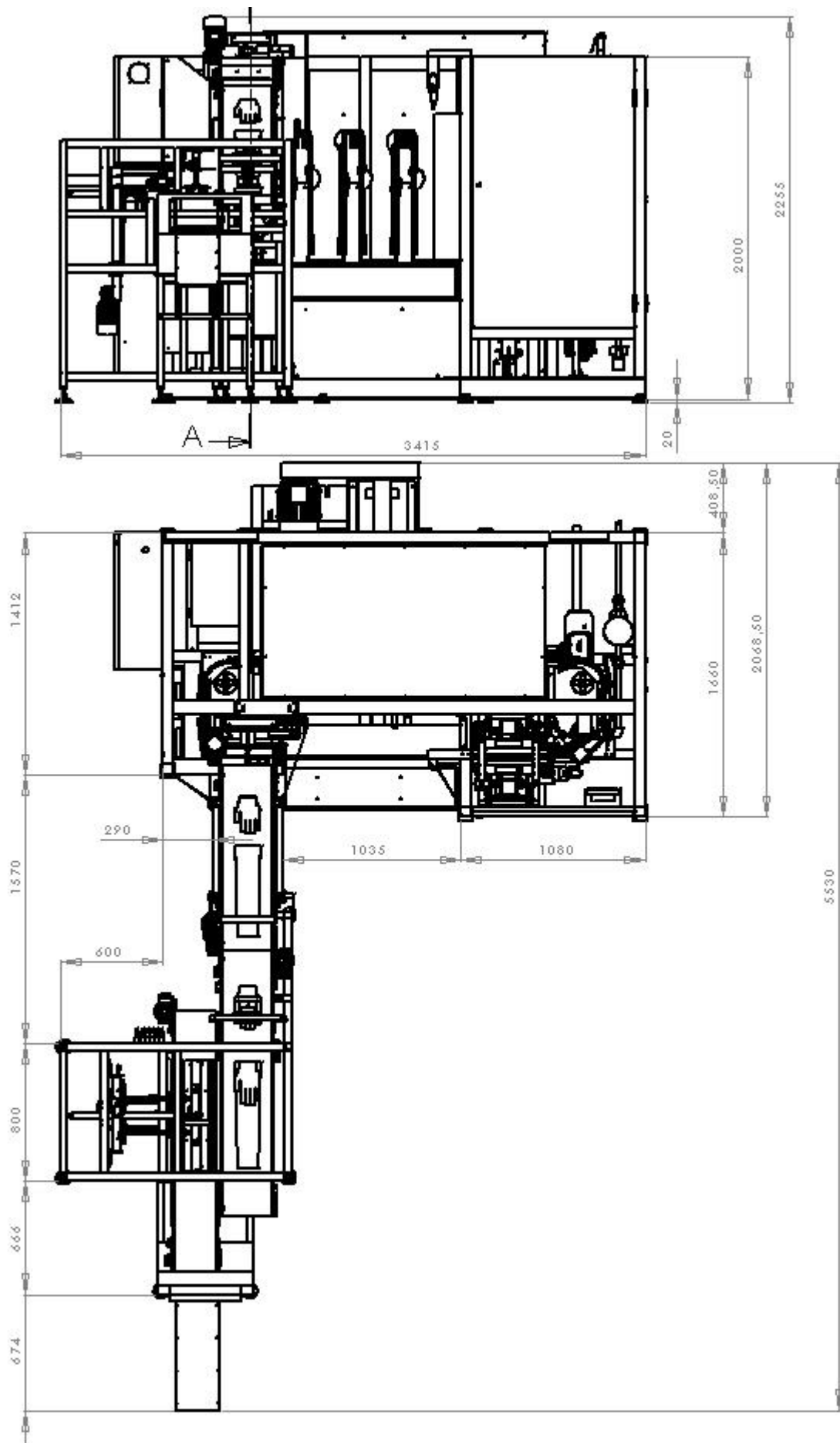

## Floor space dimensions (with stripper)

---

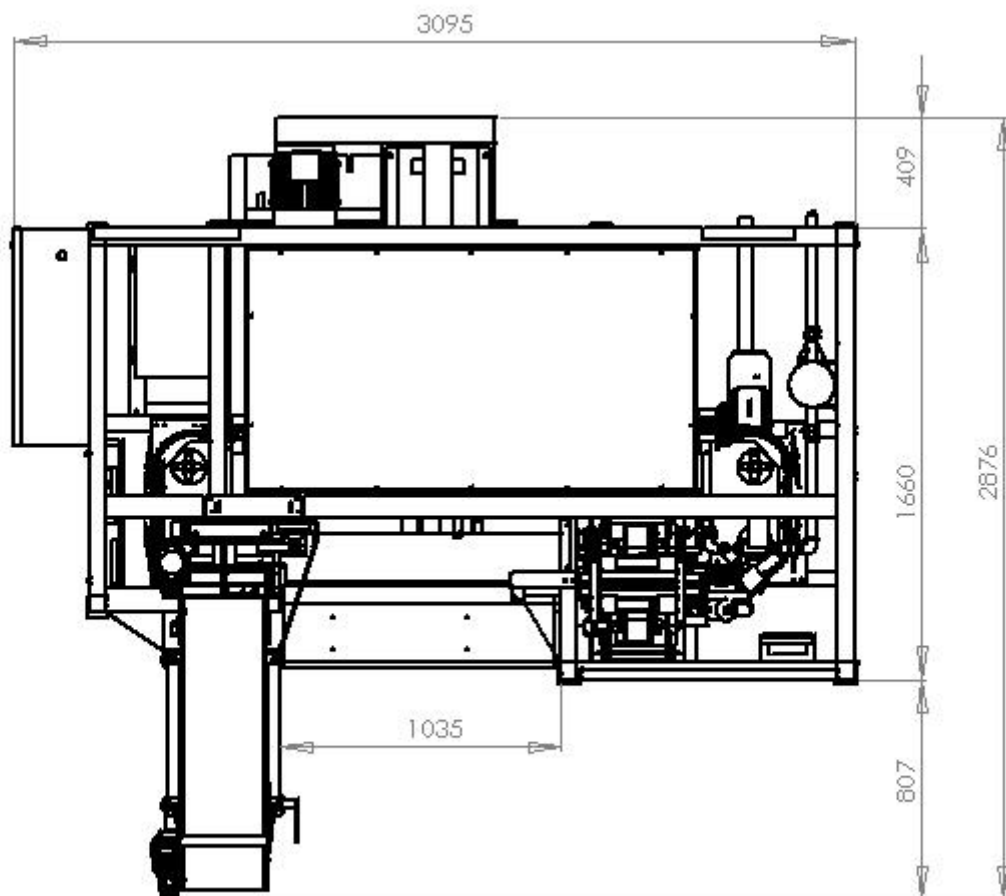
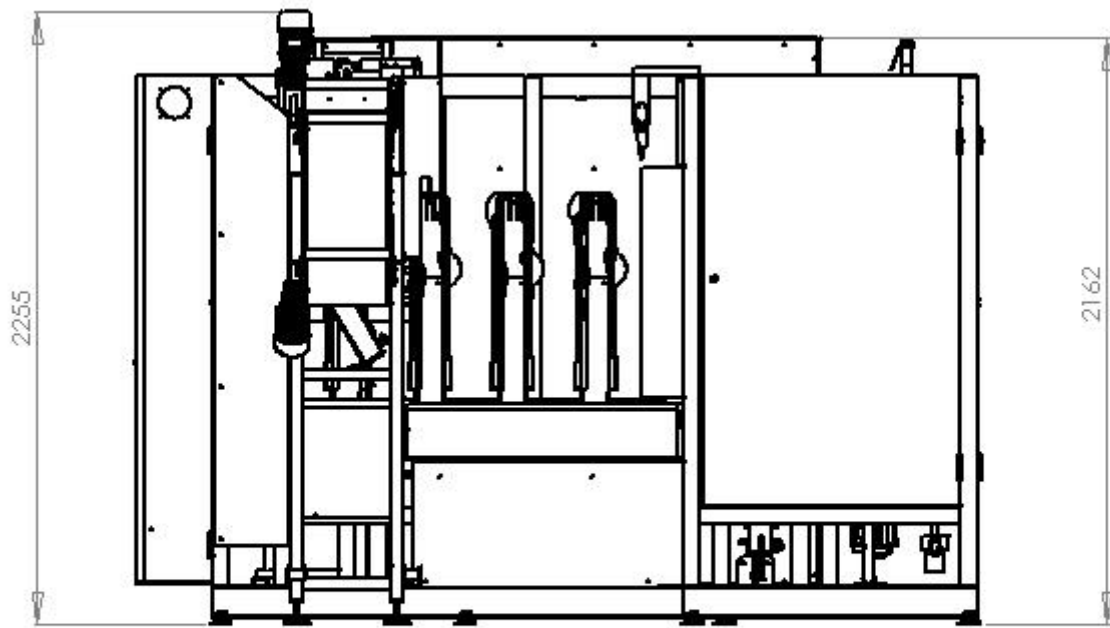

## Floor space dimensions (without stripper)

---

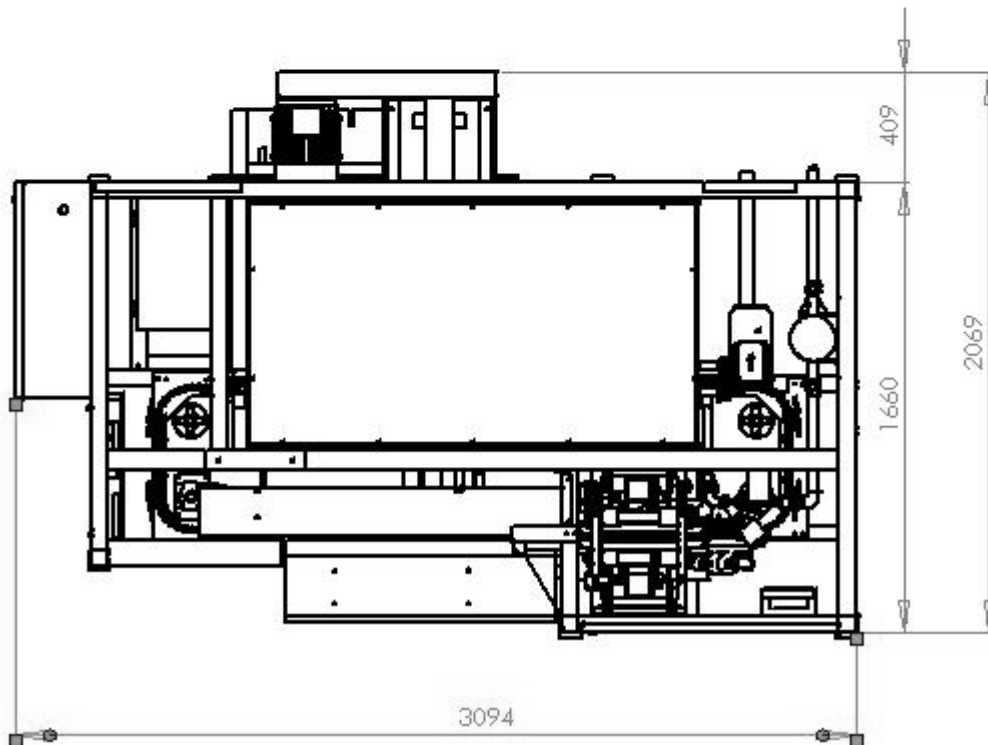
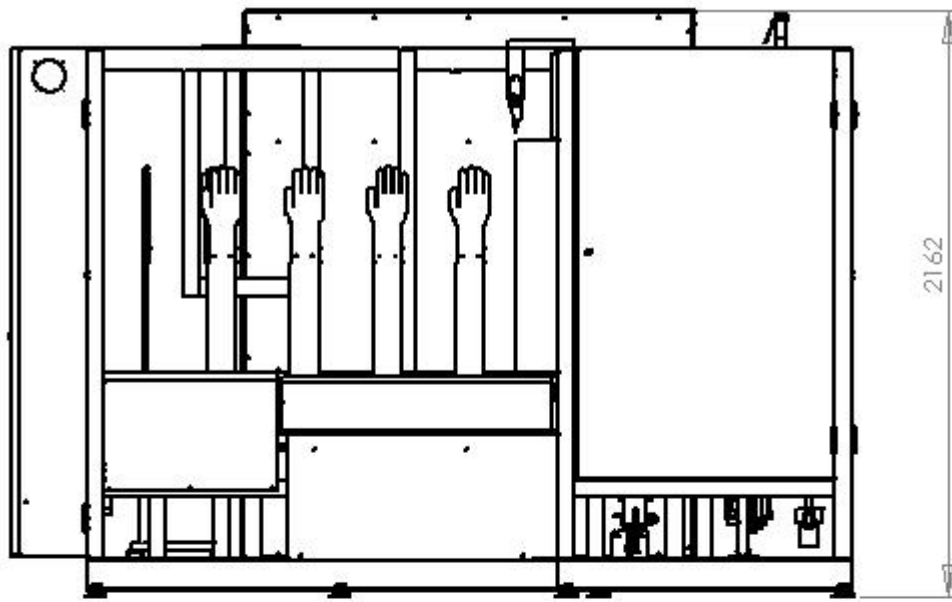

Commissioning on site is carried out by our engineers.

**E.R.M.E.S.T. sarl**  
**Rue Jean Colas – 10440 TORVILLIERS (France)**  
**www.ermest.com e-mail: [ermest@wanadoo.fr](mailto:ermest@wanadoo.fr)**  
**Tél : +33 (0) 3 25 74 34 91 - Fax : +33 (0) 3 25 79 55 48**